

Name: Box Stock Date: _____ Event: _____ Ambient Temp: _____

Track: INDOOR OUTDOOR Size: SMALL MEDIUM LARGE Traction: LOW MEDIUM HIGH

Surface: SMOOTH BUMPY RUTTED Type: LOOSE / LOAMY HARD PACKED BLUE GROOVE CLAY ASTRO

Ackerman/Bumpsteer/Servo Saver

Condition: DUSTY DRY WET MUDDY

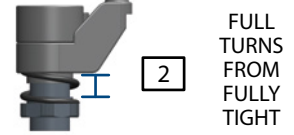
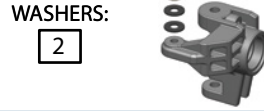

Front End:

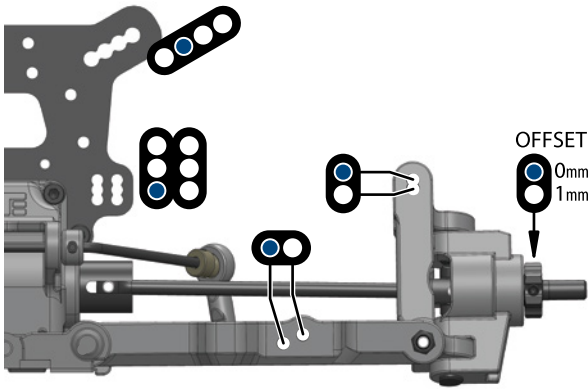

Suspension:

RIDE HEIGHT: 24 CAMBER: -2°
 CASTER BLOCK: 18° SWEEP: 0°
 KICK UP: 10° TOE: 2.0° out
 SWAY BAR: 2.1mm DROOP: 98mm

Shocks:

OIL: 700 CST BRAND: Kit
 PISTON: TKR6705E SPRING: TKR6107
 REBOUND: 0% BUILD: emul

Differentials:

OPTION	FRONT	CENTER	REAR
Diff Oil	15k	15k	10k
(TKR5145B)	<input type="radio"/>	<input type="radio"/>	<input type="radio"/>
(TKR5145C)	<input type="radio"/>	<input type="radio"/>	<input type="radio"/>
(TKR9114)	<input type="radio"/>	<input type="radio"/>	<input type="radio"/>
(TKR9114HD)	<input type="radio"/>	<input type="radio"/>	<input type="radio"/>
(TKR5114XB)	<input type="radio"/>	<input type="radio"/>	<input type="radio"/>
(TKR5150)	<input type="radio"/>	<input type="radio"/>	<input type="radio"/>
(TKR5150B)	<input type="radio"/>	<input type="radio"/>	<input type="radio"/>
(TKR5113B)	<input type="radio"/>	<input type="radio"/>	<input type="radio"/>
(TKR5113S)	<input type="radio"/>	<input type="radio"/>	<input type="radio"/>
(TKR5113)	<input type="radio"/>	<input type="radio"/>	<input type="radio"/>
(TKR5149X)	<input type="radio"/>	<input type="radio"/>	<input type="radio"/>
(TKR5149A)	<input type="radio"/>	<input type="radio"/>	<input type="radio"/>
(TKR5149)	<input type="radio"/>	<input type="radio"/>	<input type="radio"/>

Rear End:

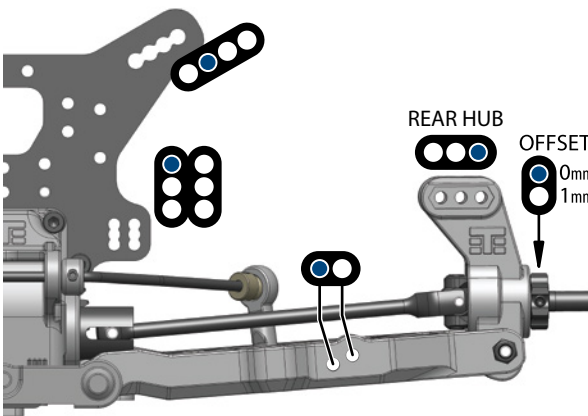

Suspension:

RIDE HEIGHT: 24 CAMBER: -2°
 ANTI-SQUAT: 1° TOE: 2.5°
 SWAY BAR: 2.1mm DROOP: 108mm

Shocks:

OIL: 600 CST BRAND: Kit
 PISTON: TKR6705E SPRING: TKR6037
 REBOUND: 0% BUILD: emul

Drivetrain:

PINION/SPUR: / 41

Equipment:

ESC: _____
 BATTERY: _____
 MOTOR: _____
 SERVO: 250 oz/in minimum

Wheelbase:

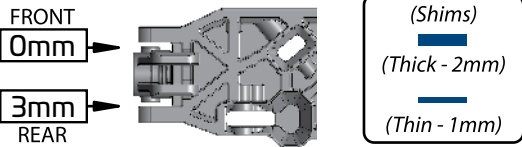

Optional Hinge Pin Braces:

"A" Block:

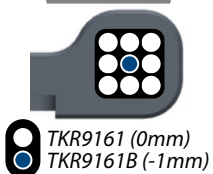

"B" Block:

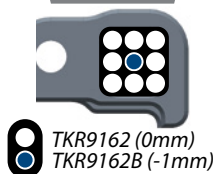

"C" Block:

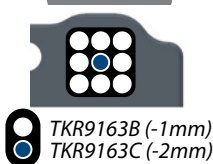

"D" Block:

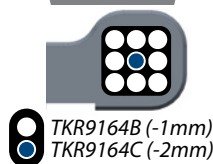

Chassis Braces:

TURNBUCKLE BRACE: CENTER BRACE:
 REAR BRACE:

Tires / Wheels:

BRAND / TREAD: _____
 COMPOUND: _____
 INSERT: _____
 WHEEL: _____
 NOTES: _____

Body/Body Mounts:

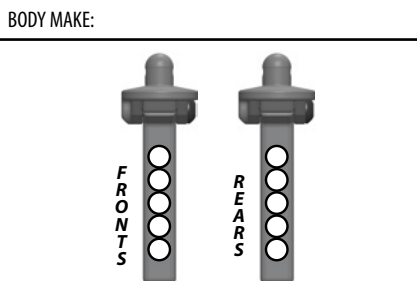

Notes: